

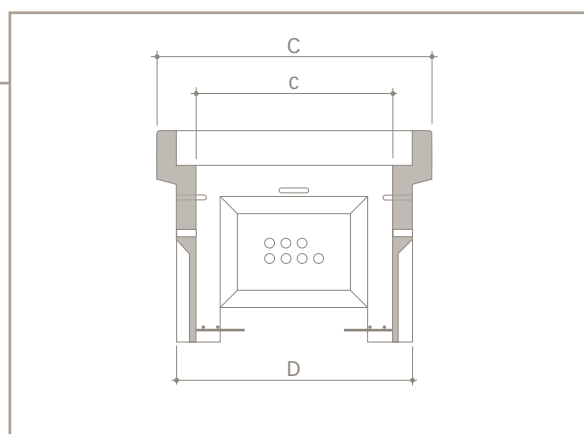

chambres télécoms

GAMME **TR** RADIER A RECONSTITUER

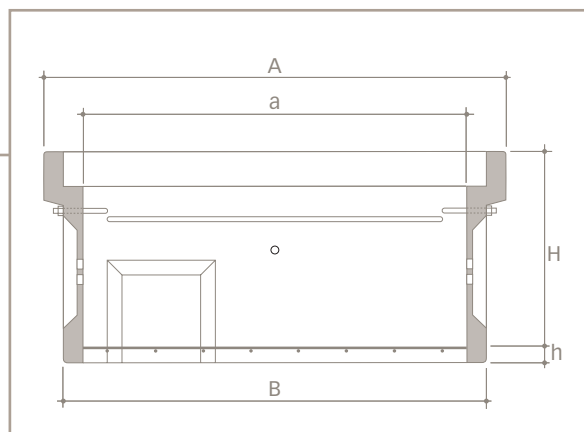
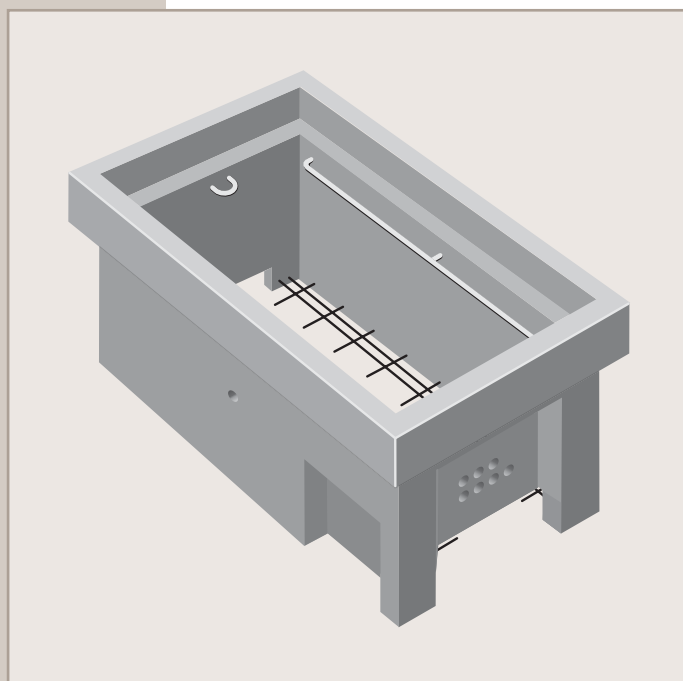

MANUTENTION :
par ancrés Artéon

Chambre	Référence		A cm	a cm	B cm	C cm	c cm	D cm	H cm	h cm	Poids kg
L0TR	CTL0TR	oui	64	42	54	46	24	36	38	8	100
L1TR	CTL1TR	oui	77	52	64,5	63	38	50,5	68	8	240
L2TR	CTL2TR	oui	141	116	128,5	63	38	50,5	68	8	440
L3TR	CTL3TR	oui	163	138	150,5	77	52	64,5	68	8	510
1/2 L4TR	CT 1/2 L4TR	oui	113	88	100,5	77	52	64,5	68	8	380
L4TR	CTL4TR	oui	204	187	199,5	69	52	64,5	68	8	680
L5TR	CTL5TR	oui	204	179	189	113	88	98	126	8	1700

